

CAD FILE:

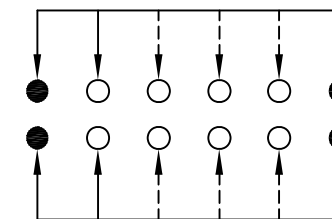

**SCHEMATIC (NON-SHORTING)**

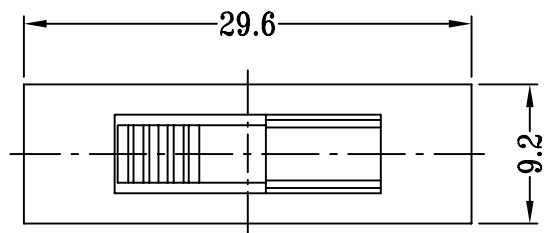
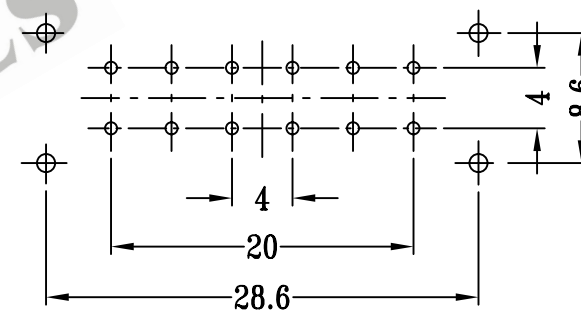
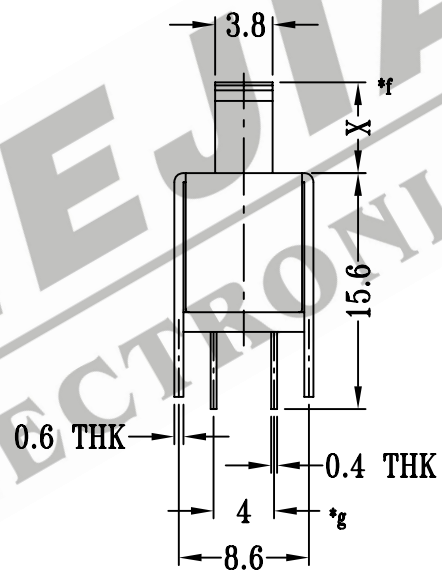
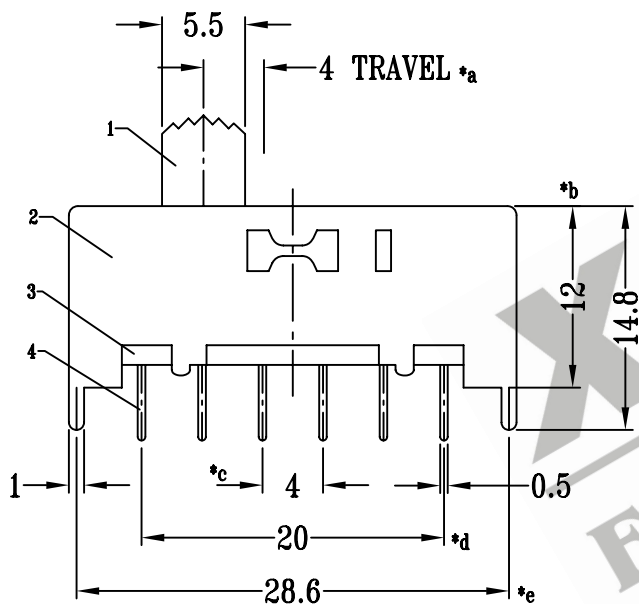

**P.C.B LAYOUT**

注:带"\*"表示关键尺寸(7个)

NO.	PARTS	MATERIALS	Q'TY	FINISH	TOLERANCE UNLESS SPECIFIED	SHENZHEN XIEJIA ELECTRONICS CO.,LTD.				
8						ISSUE	DATE	DESCRIPTIONS OF REVISION		APPD.
7	STEEL BALL	STEEL	2	NATURAL	WITHIN: 1.5±0.1mm OVER: 1.5±0.2mm					
6	SPRING	STEEL WIRE	1	TEMPER		UNIT: mm		DRWG NO.: XJ-DR-SS24H07-00		
5	CONTACT CLIP	PBS	2	Ag CLAD		SCALE: 2:1		DWN.	ZHOUYU	2002-11-19
4	TERMINAL	BRASS STRIP	12	Ag PLATED OVER Ni PLATED	TITLE: VERTICAL SLIDE SWITCH			CHK'D	FANGYING	2002-11-19
3	BASE	PHENOLIC RESIN	1	BLACK	MODEL: SS-24H07			APPD.	KANGXINAN	2002-11-19
2	FRAME	STEEL STRIP	1	Ni PLATED	ALL MATERIALS MUST BE COMPLIANT TO ROHS					
1	KNOB	POM	1	BLACK						